

සියලු ම හිමිකම් ඇවිරිණි / All Rights Reserved



විසම් පළාත් අධ්‍යාපන දෙපාර්තමේන්තුව Provincial Department of Education - NWP
 විසම් පළාත් අධ්‍යාපන දෙපාර්තමේන්තුව Provincial Department of Education - NWP
 විසම් පළාත් අධ්‍යාපන දෙපාර්තමේන්තුව Provincial Department of Education - NWP
 විසම් පළාත් අධ්‍යාපන දෙපාර්තමේන්තුව Provincial Department of Education - NWP
 විසම් පළාත් අධ්‍යාපන දෙපාර්තමේන්තුව Provincial Department of Education - NWP

තෙවන වාර පරීක්ෂණය - 13 ශ්‍රේණිය - 2023
 Third Term Test - Grade 13 - 2023

Index No.:

CHEMISTRY - I**02 Hours****Instructions:**

- Periodic Table is provided.
- Answer **all** the questions.
- Write your **Index Number** in the space provided in the answer sheet.
- Follow the instructions given on the back of the answer sheet, carefully.
- In each of the questions 1 to 50, pick one of the alternatives from (1), (2), (3), (4), (5) which is **correct or most appropriate** and **mark your response on the answer sheet with a cross (x) with the instructions given on the back of the answer sheet.**
- This paper consists of **09** pages.
- **Use of calculators is not allowed.**

Universal gas constant $R = 8.314 \text{ J K}^{-1} \text{ mol}^{-1}$ Planck's constant $N_A = 6.022 \times 10^{23} \text{ mol}^{-1}$
 Avogadro constant $h = 6.626 \times 10^{-34} \text{ J s}$ Velocity of light $C = 3 \times 10^8 \text{ m s}^{-1}$

- (01) Which of the following electronic transitions is relevant to the line with highest energy in the emission spectrum of hydrogen,
- (1) $n = 2 \longrightarrow n = 1$ (2) $n = 5 \longrightarrow n = 3$ (3) $n = 3 \longrightarrow n = 2$
 (4) $n = 5 \longrightarrow n = 2$ (5) $n = 4 \longrightarrow n = 2$
- (02) Select the incorrect statement regarding quantum numbers n , l , m_l and m_s .
- (1) n is the main quantum number, while it define the main energy level that the electron occupies in the atom.
 (2) l is the angular momentum quantum number while it defines the shape of the atomic orbital, which the electron exist.
 (3) m_l is the magnetic quantum number, which describes the orientation of the orbital in space.
 (4) m_s is the magnetic quantum number while it indicates the spinning charge produces a magnetic field, thus states two electrons con exist in an atomic orbital.
 (5) As the value of n increases, the orbital becomes larger, and electron spends more time further from the nucleus.
- (03) The increasing order of the third ionization energy ($X_{(g)}^{2+} \rightarrow X_{(g)}^{3+} + e$) of Be, N, Na and Mg.
- (1) $N < Be < Na < Mg$ (2) $Mg < Na < Be < N$ (3) $N < Na < Mg < Be$
 (4) $Na < N < Be < Mg$ (5) $Mg < Be < Na < N$
- (04) The shapes of XeF_6 , XeF_2 and $XeOF_2$ are respectively,
- (1) Square pyramidal, linear, T shape
 (2) Square planer, Pyramidal, Tetrahedral
 (3) Linear, T shape, Tetrahedral
 (4) Octahedral, Linear, Trigonal planer
 (5) Octahedral, Angular, Trigonal planer

(05) What is the IUPAC name of the following compound,

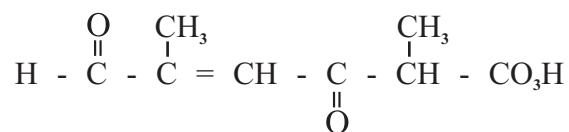

- (1) 2, 5-dimethyl-6-formyl-3-oxohex-4-enoic acid
 (2) 2, 5-dimethyl-6, 3-oxohex-4-enoic acid
 (3) 2, 5-dimethyl-3, 6-dioxo-4-hexenoic acid
 (4) 2, 5-dimethyl-3, 6-dioxohex-4-enoic acid
 (5) 3, 6-dioxo-2, 5-dimethyl-4-hexen-oic acid
- (06) Saturated aqueous solution of a sparingly soluble salt AB_3 was prepared at 25°C . Calculate the solubility product of AB_3 at 25°C , if the concentration of the B^- ion in the saturated solution is $6 \times 10^{-3} \text{ mol dm}^{-3}$.

- (1) $3.6 \times 10^{-8} \text{ mol}^2 \text{ dm}^{-6}$ (2) $4.32 \times 10^{-10} \text{ mol}^4 \text{ dm}^{-12}$
 (3) $2.16 \times 10^{-10} \text{ mol}^3 \text{ dm}^{-9}$ (4) $5.32 \times 10^{-6} \text{ mol}^2 \text{ dm}^{-12}$
 (5) $2.96 \times 10^{-10} \text{ mol}^4 \text{ dm}^{-12}$

(07) The correct variation of the covalent character in the compounds X, Y and Z is,



- (1) X < Y < Z (2) Y < X < Z (3) Z < Y < X (4) Z < X < Y (5) X < Z < Y

(08) The compounds D and E are enantiomers of each other. Which of the following is the molecular formula of D and E.

- (1) C₃H₈O (2) C₄H₈O (3) C₃H₇O (4) C₃H₆O (5) C₄H₈

(09) The increasing order of the electronegativity of central atom in the species NOCl, NH₃, NF₃, NO₄³⁻ and NO₂⁺.

- (1) NOCl < NH₃ < NF₃ < NO₄³⁻ < NO₂⁺ (2) NH₃ < NF₃ < NO₄³⁻ < NO₂⁺ < NOCl
 (3) NOCl < NH₃ < NO₄³⁻ < NO₂⁺ < NF₃ (4) NH₃ < NF₃ < NO₄³⁻ < NOCl < NO₂⁺
 (5) NH₃ < NF₃ < NO₂⁺ < NO₄³⁻ < NOCl

(10) Organic compound CH₃ - C ≡ C - H was reacted with Hg²⁺ / dil H₂SO₄. The product obtained was reacted with dil. NaOH and dehydrated. The product obtained was allowed to react with NaBD₄ / Methanol (Sodium Boro deuterite). The final product would be?

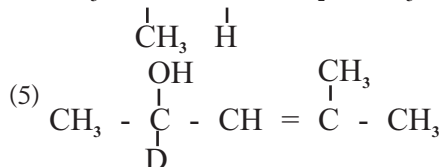
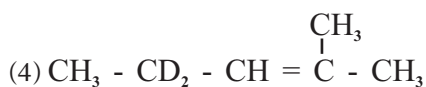
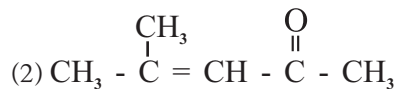
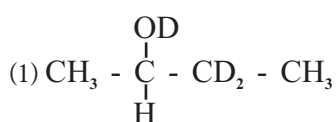

- (11) The following equilibrium occurs at 25°C in non rigid closed vessel,

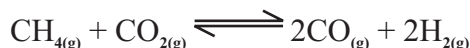

Some amount of Ne gas was inserted to the above equilibrium system at this temperature. What do you expect which does not happen in the vessel is,

- (1) Volume of the vessel increases.
 - (2) Mole fraction of the components decreases.
 - (3) No change in K_c .
 - (4) Concentration of components decreases.
 - (5) Total pressure of the vessel increases.
- (12) Experimental data of initial rates measured at given temperature of an elementary reaction $\text{A}_{(aq)} + 2\text{B}_{(aq)} \longrightarrow \text{C}_{(aq)}$ are given below,

Experiment	$[\text{A}_{(aq)}] / \text{mol dm}^{-3}$	$[\text{B}_{(aq)}] / \text{mol dm}^{-3}$	Initial rate
1	0.3	0.2	R_1
2	0.4	0.1	?

What is the initial rate of the formation of C in the second experiment?

- (1) $3R_1$ (2) $\frac{R_1}{3}$ (3) $4R_1$ (4) R_1 (5) $6R$
- (13) 6.80g of pure iron(II) sulfite (FeSO_3) salt was dissolved in excess dil H_2SO_4 . This whole solution was titrated with $0.5 \text{ mol dm}^{-3} \text{ KMnO}_4$ solution. What is the burette reading at the end point? (Fe = 56, S = 32, O = 16)
- (1) 20.0 cm^3 (2) 30.0 cm^3 (3) 40.0 cm^3 (4) 50.0 cm^3 (5) 60.0 cm^3
- (14) n moles of $\text{A}_2\text{B}_{2(g)}$ was inserted to evacuated rigid vessel of 1 dm^3 at given temperature and allow to reach the following equilibrium,

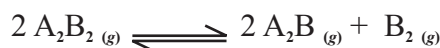

It was found x moles of $\text{B}_{2(g)}$ was produces at the equilibrium. Total pressure of the vessel at the equilibrium was P. What is the correct statement for K_p .

- (1) $\frac{4x^3 p}{(n+x)(x-2x)^2}$ (2) $\frac{4x^2 p^2}{(n+x)(n-x)^2}$ (3) $\frac{x^3 p^2}{(n+x)(n-2x)^2}$
- (4) $\frac{4x^3 p^3}{(n+x)(n-x)}$ (5) $\frac{4x^3 p}{(n-x)^2}$

- (15) The pH curve obtained for the titration of 25 cm^3 of $0.10 \text{ mol dm}^{-3} \text{ NH}_3(\text{aq})$ solution by $0.1 \text{ mol dm}^{-3} \text{ HCl}$ solution is given below. Some indicators used and pK_{In} values of them are given,

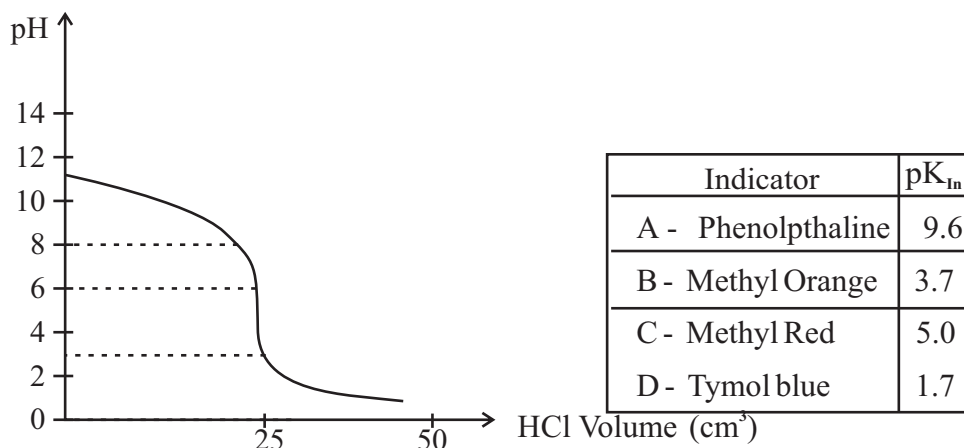

Suitable indicator for this titration are,

- (1) A and B (2) B and C (3) C and D (4) A and D (5) A and C
- (16) Which of the following statement is false regarding s block elements and the compounds formed by them,
- (1) Reducing properties of S block elements increases down the group.
 - (2) Among the alkali metals, only Li does not form stable bicarbonates in solid state.
 - (3) All the nitrates formed by alkaline earth metals release a brown coloured gas during the decomposition presence of heat.
 - (4) All hydrides of alkali metals and alkaline earth metals release H_2 gas forming the metals oxide when react with water.
 - (5) Burning of Potassium (K) in air produce superoxide as the main product and oxide and peroxide as minor products.
- (17) 50 cm^3 of $0.2 \text{ mol dm}^{-3} \text{ H}_2\text{SO}_4$ solution was added to 50 cm^3 of $0.8 \text{ mol dm}^{-3} \text{ NH}_3$ solution at 298K. What is the pH value of the solution if there is no volume change when mixing solutions. $K_b(\text{NH}_3) = 1 \times 10^{-3} \text{ mol dm}^{-3}$ at 298K.
- (1) 4.69 (2) 5.0 (3) 6.02 (4) 11.0 (5) 9.0
- (18) Consider the following reaction under standard states. What is the data which is not required to calculate ΔH° ?

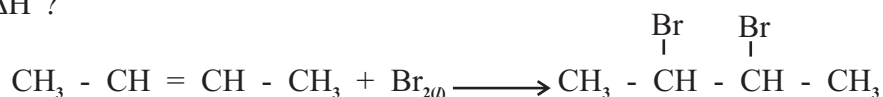

- (1) Standard bond dissociation enthalpy of C - H ($\Delta H^\circ_{\text{D}(\text{C-H})}$)
- (2) Standard bond dissociation enthalpy of C = C ($\Delta H^\circ_{\text{D}(\text{C-C})}$)
- (3) Standard enthalpy of vapourization of Br_2 ($\Delta H^\circ_{\text{vap}} \text{Br}_{2(l)}$)
- (4) Standard bond dissociation enthalpy of C - Br ($\Delta H^\circ_{\text{D}(\text{C-Br})}$)
- (5) Standard bond dissociation enthalpy of Br - Br ($\Delta H^\circ_{\text{D}(\text{Br-Br(g)})}$)

(19) Which of the following statements is incorrect with regard to a Daniel Cell?

- (1) It is a primary cell.
- (2) Oxidation half reaction occurs at the positive anode.
- (3) Cell reaction is spontaneous.
- (4) ZnSO_4 and CuSO_4 are used as the electrolytes in the cell.
- (5) The negative electrode is Zn while the positive electrode is Cu in the cell.

(20) Which of the following is not a resonance structure of phenol?

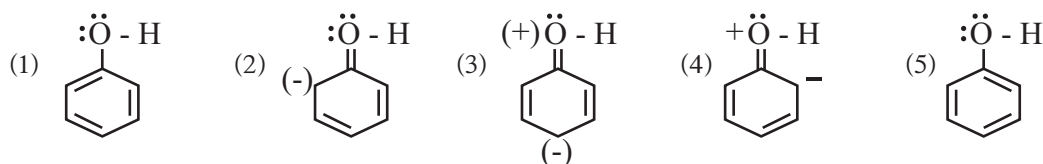

(21) Under which of the following conditions, compressibility factor $Z = \frac{PV}{nRT}$ of real gas reach approximately to 1,

- (1) Very high temperature and very high pressure.
- (2) Very low temperature and very high pressure.
- (3) Very high temperature and very low pressure.
- (4) When inter molecular attractions act very strongly.
- (5) When volume of the vessel containing the gas changes.

(22) Which of the following is true regarding two identical vessels containing two ideal gases at same temperature and pressure,

- (1) The number of moles of two gases are different.
- (2) Kinetic energy of the molecules of two gases is equal.
- (3) The number of molecules in the two gases is equal.
- (4) Volume of 1 mol of gas is 22.414dm^3 .
- (5) The same intermolecular attraction is activated among gaseous molecules X and Y.

(23) The formation of SO_3 from, SO_2 gas with atmospheric O_2 at 25C° , is a spontaneous reaction,

$2\text{SO}_{2(\text{g})} + \text{O}_{2(\text{g})} \longrightarrow 2\text{SO}_{3(\text{g})}$ The Gibbs energy change of this reaction $\Delta G^\circ = -142\text{kJmol}^{-1}$. The standard formation enthalpy values of $\text{SO}_{2(\text{g})}$ and $\text{SO}_{3(\text{g})}$ are -297kJmol^{-1} and -391kJmol^{-1} respectively. Find the maximum temperature at which this reaction happens spontaneously in C° ?

- (1) 208
- (2) 947
- (3) 1220
- (4) 1273
- (5) 1500

(24) Consider the Nucleophilic substitution reaction between ethanol and HBr. Which of the following shows a correct step in the mechanism of the reaction?

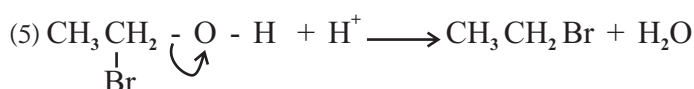
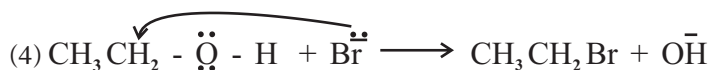
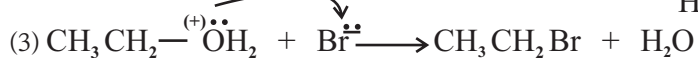
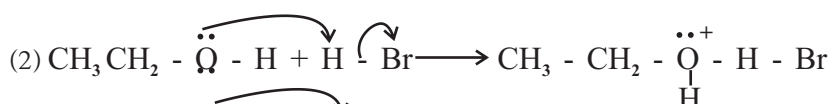
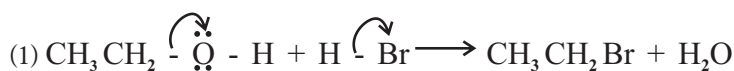

(25) If $AB_{4(g)} \rightleftharpoons A_{(g)} + 2B_{2(g)}$ $\Delta H > 0$, What you need to do to direct the reaction to the right?

- (1) The temperature of the reaction should be decreased.
- (2) Solid A should be removed from the system.
- (3) Pressure of the system should be increased.
- (4) AB_4 should be removed from the system.
- (5) None of the above.

(26) Percentage purity of 2g Magnesium strip is 84% (w/w). Solid mixture obtained by the complete combustion was added to water and the volume of NH_3 gas collected at standard temperature and pressure is 112cm^3 .

What is the mass of Mg reacted when burnt in atmosphere O_2 ?

(Volume of 1 mol of gas at STP is 22400cm^3) (R.A.M. of Mg is 24)

- (1) 1.25g (2) 1.50g (3) 1.68g (4) 1.75g (5) 2.0g

(27) The unbalanced equation relevant to the combustion of Butane ($C_4H_{10(g)}$) in an engine is given below,

$CO_2(g)$ and $CO(g)$ formed in the ratio 3: 1



Find the maximum mass of CO released by the combustion of 290g of Butane in 768g of O_2 according to the above reaction in grammes. ($C_4H_{10} = 58$, $O_2 = 32$, $CO = 28$)

- (1) 28 g (2) 56 g (3) 112 g (4) 224 g (5) 340 g

(28) Which of the following method can be used to prevent the reduction of Fe^{2+} to Fe^{3+} in an aqueous solution,

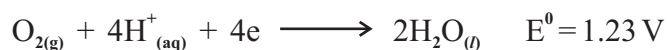

- (1) By adding a small amount of Fe^{2+} to the solution.
- (2) By adding a small amount of Fe^{3+} to the solution.
- (3) By adding a small amount of metal Ag to the solution.
- (4) By adding a small amount of Fe metal to the solution.
- (5) By bubbling O_2 gas in the solution.

(29) The products A and B in the following reaction sequence would be?

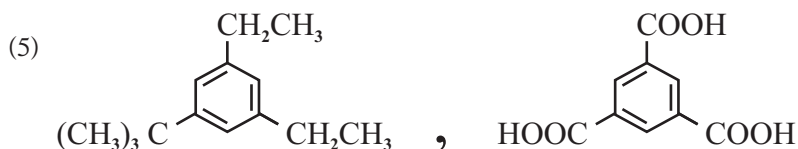
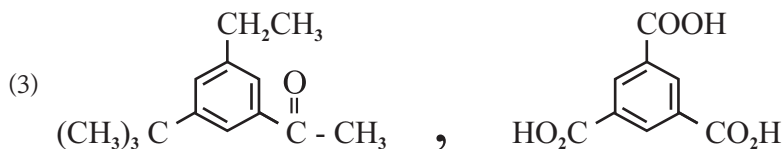
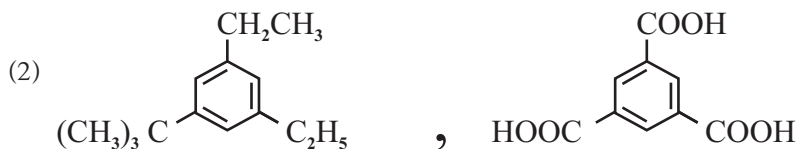
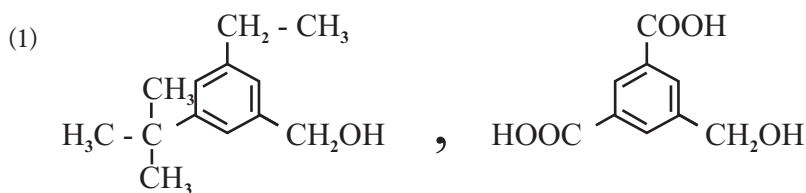
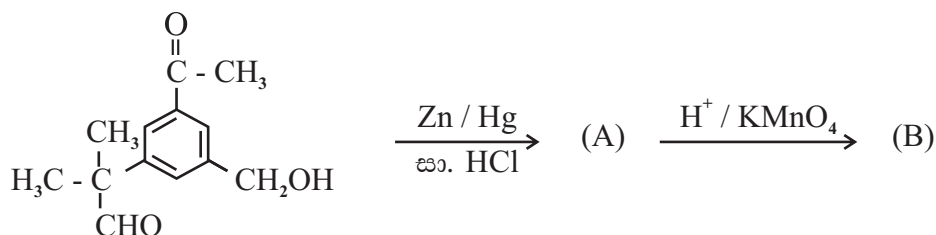

(30) Equilibrium constant of the reaction $\text{Al}^{3+}_{(\text{aq})} + 6\text{F}^{-}_{(\text{aq})} \rightleftharpoons \text{AlF}_6^{3-}_{(\text{aq})}$ at 25°C is $1 \times 10^{25} \text{ mol}^{-6} \text{ dm}^8$. What is the concentration of $\text{AlF}_6^{3-}_{(\text{aq})}$ when 25cm^3 at 0.01mol dm^{-3} $\text{Al}(\text{NO}_3)_3$ solution mixed with 25cm^3 of 0.10mol dm^{-3} NaF solution in mol dm^{-3} ,

- (1) 1×10^{-3} (2) 2×10^{-3} (3) 3×10^{-3} (4) 4×10^{-3} (5) 5×10^{-3}

- For each of the questions 31 to 40, one or more responses out of the four responses (a), (b), (c) and (d) given is/are correct. Select the correct response/responses in accordance with the instructions given on your answer sheet, mark.

- (1) If only (a) and (b) are correct.
- (2) If only (b) and (c) are correct.
- (3) If only (c) and (d) are correct.
- (4) If only (d) and (a) are correct.
- (5) If any other number of combination of responses is correct.

Summary of above Instructions,

(1)	(2)	(3)	(4)	(5)
Only (a) and (b) are correct	Only (b) and (c) are correct	Only (c) and (d) are correct	d Only (a) and (d) are correct	Any other number or combination of responses is correct

- (31) To which of the following is/are affected by the temperature for a given chemical reaction?
- (a) Collision frequency of reactant molecules.
 - (b) Kinetic energy of collision molecules.
 - (c) Standard enthalpy change of the reaction at 25⁰C.
 - (d) Activation energy of the reaction.

- (32) Consider the reaction mechanism of the following reaction.

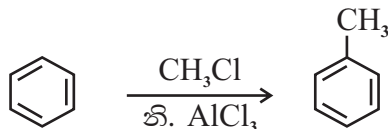

Which of the following is/are formed during this reaction,

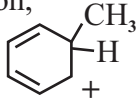
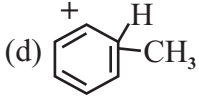
- (a) $[\text{AlCl}_4]^-$ (b) $^+\text{CH}_3$ (c)  (d) 
- (33) 2g of SrSO_4 was stirred in 1 dm³ of water at 25⁰C to obtained a saturated solution while 0.163g of the salt remains undissolved. Which of the following is/are true regarding this system?
(Sr = 88, S = 32, O = 16)
- (a) The maximum amount of SrSO_4 dissolved in the solution is 1×10^{-3} mol.
 - (b) When twice the volume of the solution the concentration of Sr^{2+} is 2×10^{-3} mol dm⁻³.
 - (c) Ionic product of the solution is lower than the solubility product.
 - (d) When twice the volume of the solution concentration of SO_4^{2-} is 5×10^{-4} mol dm⁻³.
- (34) Which of the following is/are true regarding the complex ions formed by 3d series elements.
- (a) Aqueous solutions of both elemental cations Ni^{2+} and Cu^{2+} form dark blue colour solutions with excess NH_4OH .
 - (b) Complex ions formed by Cu^{2+} , Ni^{2+} and Fe^{3+} with conc. HCl is yellow colour.
 - (c) Aqueous solutions of complex chlorides formed by Mn^{2+} and Co^{2+} are blue colour.
 - (d) Mn^{2+} and Zn^{2+} form colourless water soluble amine complexes with excess NH_4OH .

- (35) Which of the following statement/(s) is/are true?
- The boiling point of 2,2-dimethylpropane is higher than that of pentane.
 - The boiling point of propanone is slightly higher than that of propanal.
 - The boiling point of butanoic acid is lower than of butan-2-one.
 - The boiling point of pentane is lower than that of pentanol.
- (36) Which of the following statements is/are true regarding the Oxo acids of S (Sulfur)?
- There are two S atoms with sp^2 hybridization in Thiosulfuric acid.
 - Sulfurous acid has one S atom with sp^2 hybridization.
 - Concentrated sulfuric acid is a dehydrating agent as well as strong oxidizing agent.
 - Thiosulfuric acid is a weak acid while only its salts are stable.
- (37) Which of the following is/are true regarding photochemical smog?
- NO gas is released from internal engine during combustion of fuel .
 - Photolysis of NO_2 form atomic 'O' presence of sunlight in the atmosphere.
 - Suspended dust particles in the atmosphere cause photochemical smog.
 - Long chain aldehydes are contributed to the occurrence of photochemical smog.
- (38) Distribution coefficient of pesticide X between ether and water is 4. X is more soluble in ether. To separate 20g of X contains in 100cm^3 of water, it was extracted twice consecutively by adding 100cm^3 of ether in each time. Which of the following is/are true,
- Mass of X displaced to ether layer from water layer is 19.2g.
 - Mass of X remains at the first time in the aqueous layer is 4g.
 - Mass of x remains in the water layer at the end of the extraction is 0.8g.
 - The total mass of X extracted to the ether layer at the end of the extraction is 20g.
- (39) Which of the following is/are true regarding the experiment done by students to determine the dissolved oxygen (DO) in pond water?
- Sample from the top water layer of the pond was filled into a reagent bottle.
 - Dissolved O_2 in water was fixed by adding $MnSO_{4(aq)}$ and basic KI soon after collecting the sample.
 - Here dissolved O_2 in water Oxidize Mn^{2+} to MnO_2 .
 - During the titration with $Na_2S_2O_3$ at the laboratory, colour change at the end point is blue \rightarrow colourless.
- (40) Which of the following is/are true regarding the chemical processes given below.
- NaOH can produced by electrolysis of conc. Bittern solution during the production of caustic soda.
 - It is an advantage that K_{sp} of $Mg(OH)_2$ is higher than the K_{sp} of $Ca(OH)_2$ during the extraction of Magnesium.
 - The system becomes hot due to the evolution of heat during the saponification step of the production of soap.
 - The efficiency of the dissolution of NH_3 decreased due to the ammonification of brine solution is exothermic, when producing Na_2CO_3 from ammoniac-soda method.

- In question numbers 41 to 50, two statements are given in respect of each question.

1st statement	2nd statement	Response
True	True and 1st is explained correctly	1
True	True and 1st is not explained correctly	2
True	False	3
False	True	4
False	False	5

1st statement	2nd statement
(41) The correct increasing order of the boiling points of hydrogen halides is, $\text{HCl} < \text{HBr} < \text{HI} < \text{HF}$	Boiling point of hydrogen halides increased when the electronegativity of halogen increases.
(42) Sulfuric acid is formed when S react with conc. HNO_3 acid.	Conc. HNO_3 act as oxidizing agent producing NO_2 .
(43) Galvanic cell formed by using the common electrolyte as HCl , standard hydrogen electrode and standard silver / silver chloride electrode is represented as, $\text{Pt} / \text{H} / \text{H}^+_{(\text{aq}, 1 \text{ mol dm}^{-3})} / \text{Cl}^-_{(\text{aq}, 1 \text{ mol dm}^{-3})} / \text{AgCl}_{(\text{s})} / \text{Ag}_{(\text{s})}$	When there is a common electrolyte between two electrodes, there is no liquid junction potential.
(44) Grignard reagent act as a Neucophile with carbonyl compounds.	The Carbon atom in the carbon - magnesium bond of Grignard reagent has a partial negative charge.
(45) The aromatic diazonium salts show electrophilic substitution reaction, with phenol, presence of NaOH as a catalyst.	The type of Orange colour dye is formed due to the substitution of diazonium salt instead of H atoms in ortho places.
(46) If the enthalpy change of a solution formed by mixing two solutions that are completely miscible at given temperature is negative, that solution is an ideal	When mixing two solution,s the enthalpy change is negative for the solutions that have a positive deviation from the Rault's law.
(47) CFC and HCFC contribut to ozone layer depletion, while HFC does not.	HFC does not have the ability to form chlorine free radicals.
(48) The initial rate and the rate constant of zeroth order reaction respectively are R_0 and k . When the initial concentration decreases by 50%, rate of the reaction is also k .	Since the rate of zeroth order reaction does not depend on the concentration of the reactant, rate of the reaction is equal to the rate constant.
(49) Bio diesel produced by using bio methanol is 100% a renewable saource of fuel.	The process of producing bio diesel is trans esterification process.
(50) Teflon is an addition polymer while the repeating unit is $\text{—}[\text{CF}_2 - \text{CF}_2]_n\text{—}$	The molar mass of the monomer is equal to the molar mass of the repeating unit of the additive polymers.

සියලු ම හිමිකම් ඇවිරිණි / All Rights Reserved



විසම් පළාත් අධ්‍යාපන දෙපාර්තමේන්තුව Provincial Department of Education - NWP
 විසම් පළාත් අධ්‍යාපන දෙපාර්තමේන්තුව Provincial Department of Education - NWP
 විසම් පළාත් අධ්‍යාපන දෙපාර්තමේන්තුව Provincial Department of Education - NWP
 විසම් පළාත් අධ්‍යාපන දෙපාර්තමේන්තුව Provincial Department of Education - NWP
 විසම් පළාත් අධ්‍යාපන දෙපාර්තමේන්තුව Provincial Department of Education - NWP
 විසම් පළාත් අධ්‍යාපන දෙපාර්තමේන්තුව Provincial Department of Education - NWP

තෙවන වාර පරීක්ෂණය - 13 ශ්‍රේණිය - 2023
 Third Term Test - Grade 13 - 2023

Index No.:

CHEMISTRY - II**03 hours**

Extra reading time 10 minutes

Use **additional reading time** to go through the question paper, select the questions **and** decide on the questions that you give priority in answering.

- A Periodic Table is provided on page 15.

- **Use of calculators is not allowed.**

Universal gas constant $R = 8.314 \text{ J K}^{-1} \text{ mol}^{-1}$ Planck's constant $N_A = 6.022 \times 10^{23} \text{ mol}^{-1}$
 Avogadro constant $h = 6.626 \times 10^{-34} \text{ J s}$ Velocity of light $C = 3 \times 10^8 \text{ m s}^{-1}$

- **In answering this paper, you may represent alkyl groups in a condensed manner.**

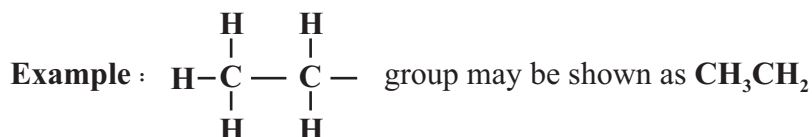
**PART A - Structured Essay (page 02 - 08)**

- Answer all the questions on the question paper itself.
- Write your answer in the space provided for each question. Please note that the space provided is sufficient for the answer and that extensive answers are not expected.

PART B and PART C - Essay (page 09 - 14)

- Answer four questions selecting two questions from each part. Use the papers supplied for this purpose.
- At the end of the time allotted for this paper, tie the answers to the three Parts **A**, **B** and **C** together so that Part A is on top and hand them over to the Supervisor.
- You are permitted to remove only Parts **B** and **C** of the question paper from the Examination Hall.

For Examiner's Use Only

Part	Question No.	Marks
A	1	
	2	
	3	
	4	
B	5	
	6	
	7	
C	8	
	9	
	10	
Total		

Total

In Numbers	
In Letters	

Code Numbers

Marking Examiner 1	
Marking Examiner 2	
Checked by :	
Supervised by :	

Structured Essay**PART - A**

- (01) (a) State whether the following statements are true or false on the dotted lines. Reasons are not required.
- (i) The frequency difference between first two lines of Lyman series is equal to the frequency of the second line of Balmer series
- (ii) There are only 07 electrons in Copper atom with the azimuthal quantum number $l = 0$
- (iii) The number of Lewis dot dash structures (resonance structures) that can be drawn for the NO_2 molecule is three
- (iv) Among the elements F and Cl, F has the highest negative value of electron gain energy
- (v) The boiling point of CCl_4 is higher than that of CHCl_3 ,
- (vi) B has the highest first ionization energy among the elements Li, Be and B
- (b) The skeleton of a molecule containing only the elements O, N and F is given below.



- (i) Draw the most acceptable Lewis dot-dash structure for this molecule.
- (ii) Give
- (1) shapes around the N_1 and N_2 atoms and
- (2) oxidation numbers of the atoms in the structure drawn above.
- 1) N_1 N_2 (shape)
- 2) N_1 N_2 (oxidation number)
- (iii) A Lewis dot dash structure for the CO_4^{2-} is given below. Draw three more Lewis dot dash structures (Resonance structures) for the CO_4^{2-} ion.

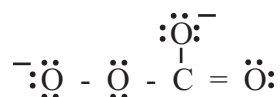

(iv) Complete the given table based on the Lewis dot-dash structure and its labelled skeleton

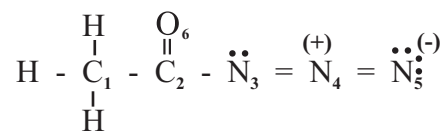

	C ₁	C ₂	N ₃	N ₄
(I) The number of VSEPR pairs around the atom				
(II) Electron pair geometry around the atom				
(III) Shape around the atom				
(IV) Hybridization of the atom				

- **Parts (v) to (viii) are based on the Lewis dot-dash structure given in part (iv) above. Labelling of atoms is as in part (iv).**

(v) Identify the atomic/hybrid orbitals involved in the formation of σ bonds between the two atoms given below.

- (I) H - C₁ H - C₁ -
- (II) C₁ - C₂ C₁ - C₂ -
- (III) C₂ - N₃ C₂ - N₃ -
- (IV) N₃ - N₄ N₃ - N₄ -
- (V) N₄ - N₅ N₄ - N₅ -

(vi) Identify the atomic orbitals involved in the formation of π bonds between the atoms given below.

- (I) N₃ - N₄ N₃ - N₄ -
- (II) N₄ - N₅ N₄ - N₅ -
- (III) C₂ - O₆ C₂ - O₆ -

(vii) Arrange the following species in the increasing order of the property indicated in parentheses. Reasons are not required.

- (I) MgF₂, MgCl₂, MgBr₂, MgI₂ (covalent character)
 < < <
- (II) NH₄⁺, NH₂⁻, H₂O, H₃O⁺ (Bond Angle)
 < < <
- (III) Be²⁺, Li⁺, S²⁻, Cl⁻ (Ionic Radius)
 < < <

(IV) $\text{CO}_2, \text{CO}, \text{CO}_3^{2-}, \text{HCOO}^-$ (C-O bond length)

..... < < <

(V) Li, N, Na, F, Cl (First ionization energy)

..... < < < <

(02) (a) The questions (i), (ii), (iii) are based on the following reactions.

A is an ionic compound composed of three elements in the ratio 1 : 2 : 4 (Not in the order of the chemical formula) One of these is a d block element that belong to the fourth period of the periodic table. When an aqueous solution of A was acidified with an acid D, which is a diprotic acid and strong dehydrating agent produces an orange colour solution B.

B is also on ionic compound composed of the same three elements as in A. B dissolves in water to given an orange colour solution.

C is a non metal which reacts with D producing tri-atomic gas E with pungent smell. The gas E changes the colour of an aqueous solution of B in acidic medium giving green colour solution.

G is a gas which changes the colour of red litmus to blue act as an oxidizing agent as well as reducing agent.

H is composed of 3 elements, When H is subjected to the flame test a yellow flame is observed. Excess amount of H reacts with amphoteric element I producing diatomic gas J.

K is composed of three elements and the cation in K and H is identical. When an aqueous solution of K is treated with H and I it produces gas G.

L is a viscous colourless liquid composed of two elements. It dispraportionates easily. L act as oxidizing agent as well as reducing agent. When an aqueous solution of the cation of the d block element in A or B is treated with H followed by adding L produces yellow colour solution.

(i) Identify A to I. (Note: Write the chemical formula)

A - D -

G - B -

E - C -

F - G -

H - I -

J - K -

L -

- (ii) Give balanced chemical equations for the following. (Physical states not required)
- (I) Formation of E from C and D.

- (II) Formation of gas G from H, I and K.

- (III) Formation of yellow colour solution from the aqueous solution of d block cation in A/B with H followed by L.

- (iii) Give balanced ionic equations for the reactions that takes place when B is reacted with the following solutions. (Physical states not required)
- (I) With E in acidic medium.

- (II) When adding H drop wise.

- (vi) (I) Write the colour of the aqueous solution formed by the d block element contains in A or B?

- (II) Write the chemical formula of (I).

- (III) Write the balanced ionic equation when aqueous solution of G is added to above aqueous solution in (II).

- (IV) Write any observation in III above.

- (b) Give balanced chemical / ionic equations for the reactions that takes place between the following (physical states not required)
- (i) L with MnO_4^- in acidic medium.....
 Function of L:
- (ii) G with Na
- Function of G a -
 b -
- (iii) Hydride of C and E.....
- a. Function of E :
- b. Function of the Hydride of C :
- (vi) C and D :
- Function of D :

- (03) (a) (i) Write the equation to show that pressure is proportional to the mean square speed of molecules in a given container at a given temperature.

.....

- (ii) According to the above equation what do you expect when molecular speed increases?

.....

- (iii) Use the equation in (i) above to show temperature dependence of the speed of molecules.

.....

- (iv) Show the variation of the speed of three gases Cl_2 , N_2 and H_2 at 300K in the figure given below. Indicate clearly the gas corresponding to each curve.



- (b) The elementary steps of a proposed reaction mechanism are represented below.

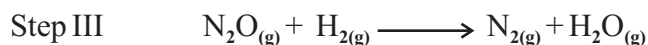
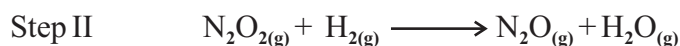

- (i) Write the overall reaction for the mechanism given above.

.....

- (ii) Giving reasons identify intermediate product/(s) of above mechanism.

.....

- (c) The following graphs were obtained from an experiment carried out in relation to the overall reaction in (i) above, at temperature T. Rates and concentrations are measured in units of $\text{mol dm}^{-3} \text{ s}^{-1}$ and mol dm^{-3} .

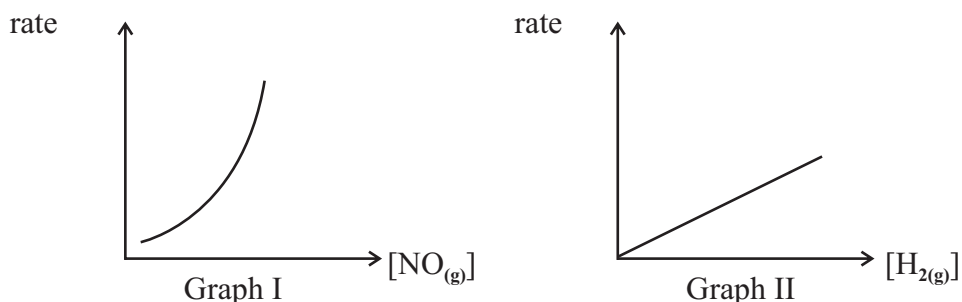

Graph I - was obtained by keeping $[\text{H}_{2(g)}]$ constant

Graph II - was obtained by keeping $[\text{NO}_{(g)}]$ constant

- (i) a) With the help of graphs 1 and 2, deduce orders of the reaction with respect to $[\text{NO}_{(g)}]$ and $[\text{H}_{2(g)}]$

.....

- b) What is the overall order of the reaction?

.....

- c) Predict the rate determining step of the reaction among three steps.

.....

- (ii) If the rate constant of the reaction is k at temperature T, write the rate law of the reaction.

.....

- (iii) Derive the unit of k.

.....

- (iv) In an experiment carried out at temperature T, the concentration of $\text{NO}_{(g)}$ and $\text{H}_{2(g)}$ were $0.2 \times 10^{-1} \text{ mol dm}^{-3}$ and $0.2 \times 10^{-2} \text{ mol dm}^{-3}$ respectively. The rate of the reaction was found to be $0.8 \times 10^{-3} \text{ mol dm}^{-3} \text{ s}^{-1}$. Calculate the rate constant of the reaction.

.....

- (04) (a) A, B, C are structural isomers having the molecular formula $C_5H_{12}O$ of these three isomers, only B exhibits optical isomerism. A and C are positional isomers of each other. When A, B and C are reacted separately with pcc, C did not react with PCC. A and B reacted with PCC and give D and E respectively. Both D and E gave coloured precipitates with 2, 4 - DNP and silver mirror with Ammonical $AgNO_3$. When D and E reacted with CH_3MgBr followed by (H^+/H_2O) , gave F and G. When F and G dehydrated separately with conc. H_2SO_4/Δ gave H and I respectively.

- (i) Draw the structures of A, B, C, D, E, F, G, H and I in the boxes given below.

A	B	C
D	E	F
G	H	I

- (ii) Describe a chemical test to distinguish B, C and F from one another.

.....

.....

.....

.....

.....

.....

.....

- (b) (i) Draw the structures of the products J, K, L, M and N of the following reactions (i to v) in the given boxes.

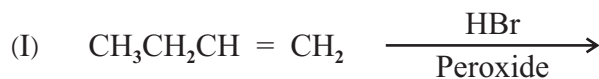

J

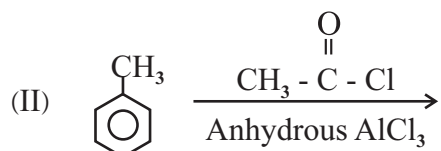

K

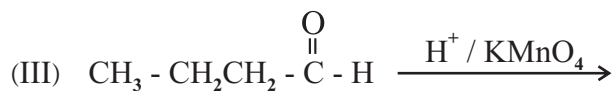

L

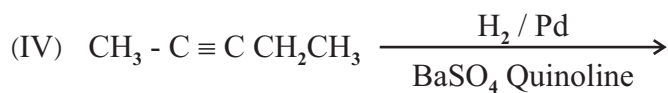

M



N



- (ii) Selecting from the reaction (i) - (v) given one example each for each type of reaction given below.

a) Electrophilic substitution

b) Oxidation Reaction

c) Nucleophilic addition reaction

PART - B

• **Answer two questions only.**

(05) (a) The compound $QR_{5(g)}$ decomposes temperatures above 500K is as follows.

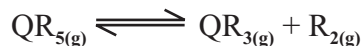

0.5 mol of $QR_{5(g)}$ was inserted into a closed rigid vessel at 300K, while the pressure of the vessel is 5×10^5 pa. When the temperature of the vessel which containing $QR_{5(g)}$ was increase to 601 K, pressure of the vessel increases to 14.03×10^5 pa (The product RT at 601 K is 5000 Jmol^{-1})

- Find the number of moles of $QR_{5(g)}$, $QR_{3(g)}$, $R_{2(g)}$ separately at the equilibrium system.
 - Calculate the K_p for the above reaction at 601 K.
- (b) Weak acid HA was distributed among water and CCl_4 . HA does not dissociates in CCl_4 . When an aqueous solution of HA was mixed well with CCl_4 at 27°C , and let it to reach the equilibrium. The concentration of HA in the CCl_4 layer is 0.4 moldm^{-3} . If Distribution coefficient of HA in CCl_4 and water is 20 and the pH value of the aqueous layer remains in 4.0.
- Calculate the $HA_{(aq)}$ concentration in the aqueous layer.
 - Calculate the K_a of HA at 27°C .
- (c) $2CO_{(g)} + O_{2(g)} \longrightarrow 2CO_{2(g)}$ The following reaction was carried out under constant temperature, while the data required to determine the order with respect to each reactant was observed as follows.

	Experiment Number		
	1	2	3
Initial pressure of $CO_{(g)}$ and $O_{2(g)}$ mixture / Nm^{-2}	2×10^5	2.5×10^5	2.7×10^5
Initial pressure of $CO_{(g)}$ / Nm^{-2}	0.5×10^5	0.5×10^5	1.2×10^5
Initial Rate $\text{Nm}^{-3} \text{S}^{-1}$	3.6×10^5	4.8×10^5	3.6×10^5

- Determine the orders with respect to $CO_{(g)}$ and $O_{2(g)}$ and the overall order.
 - Write the rate equation.
 - Calculate the rate constant at this temperature.
- (06) (a) For the reaction $RS_2N_{3(g)} \longrightarrow RN_{3(g)} + S_{2(g)}$ at 300K, $\Delta H = +68 \text{ KJmol}^{-1}$. Entropy values for $RS_2N_{3(g)}$, $RN_{3(g)}$ and $S_{2(g)}$ are $362 \text{ JK}^{-1} \text{ mol}^{-1}$, $220 \text{ JK}^{-1} \text{ mol}$ and 324 JK mol^{-1} respectively.
- Show whether the above reaction is spontaneous or not at 300K temperatures with suitable calculation.
 - If it is not spontaneous calculate the minimum temperature that the reaction occur spontaneously.

(b) There is an equilibrium mixture containing CH_3COOH and $\text{C}_2\text{H}_5\text{COOH}$ at 25°C . Concentration of $\text{CH}_3\text{COOH}_{(\text{aq})}$ is 0.2 mol dm^{-3} and the concentration of $\text{C}_2\text{H}_5\text{COOH}$ is 0.1 mol dm^{-3} . K_a values of $\text{CH}_3\text{COOH}_{(\text{aq})}$ and $\text{C}_2\text{H}_5\text{COOH}_{(\text{aq})}$ are $1.8 \times 10^{-5} \text{ mol dm}^{-3}$ and $1.3 \times 10^{-5} \text{ mol dm}^{-3}$ respectively.

- (i) Find the pH of this equilibrium system.
- (ii) Calculate the concentrations of $\text{CH}_3\text{COO}^-_{(\text{aq})}$ and $\text{C}_2\text{H}_5\text{COO}^-_{(\text{aq})}$ separately in this mixture.

(c) (i) A solution was prepared by mixing 25.00 cm^3 of 0.2 mol dm^{-3} HCN solution and 25.00 cm^3 of 0.1 mol dm^{-3} NaOH solution. Show that $[\text{H}^+_{\text{aq}}] = K_{a\text{HCN}}$ in this solution.

- (ii) Explain whether the above HCN , NaOH mixture act as buffer solution, giving reasons.

(07) (a) (i) Write the electrode reaction for the standard silver / silver chloride electrode.

- (ii) Write the cell reaction prepared by using the above electrode and the standard chlorine gas electrode.

$$E^0_{\text{AgCl(s)}/\text{Ag(s)}} = +0.80 \text{ V}$$

$$E^0_{\text{Cl}_2(\text{aq})/\text{Cl}^-_{(\text{aq})}} = +1.36 \text{ V}$$

- (iii) Write cell notation in the IUPAC method for the above reaction.

- (iv) Calculate the standard Electro motive force of the above cell.

(b) There are only two ligands in a complex compound formed by metal cation of the metal M exist as the central atom. For 1 mol of the complex compound there is one mole of central atom and four moles of NH_3 . The only other element in this compound belongs to group 17. 0.05 mol of this compound was dissolved in distilled water and when adding excess AgNO_3 gives dark yellow precipitate, which does not dissolve in dilute or concentrated NH_3 . Dry mass of the precipitate is 11.75 g . This complex is octahedral. ($\text{Ag} - 108$, $\text{Cl} - 35.5$, $\text{Br} - 80$, $\text{I} - 127$)

- (i) What is the other ligand exist in the compound other than NH_3 ?
- (ii) Write the chemical formula of the compound by determining the charge of the complex ion.
- (iii) $+2$ and $+3$ oxidation states of metal M are highly stable while $+2$ oxidation number gives a pink colour in an aqueous solutions. Further M^{2+} form blue colour complex with conc. HCl . Write the chemical formula of the above complex compound using symbols of relevant elements.
- (iv) Write the chemical formulae of the species responsible for pink and blue colours in (iii) above, and write IUPAC names of them.

(c) 20 A current was passed through 30 minutes, during the electrolysis done by dipping two inert electrodes in Zinc sulfate solution. Zn was deposited on the Cathode while H_2 gas was released. 60% of current was consumed to deposit Zn.

(i) Write the equations for the reactions occur at the cathode.

(ii) Write the equations for the reactions occur at the Anode.

(iii) What is the mass of Zn deposited?

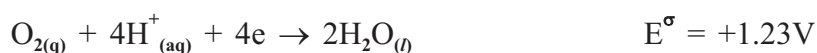
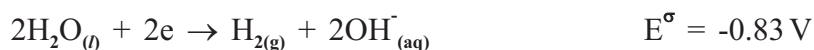

PART - C

• Answer two questions only.

(08) (a) Show how you do the following conversion.

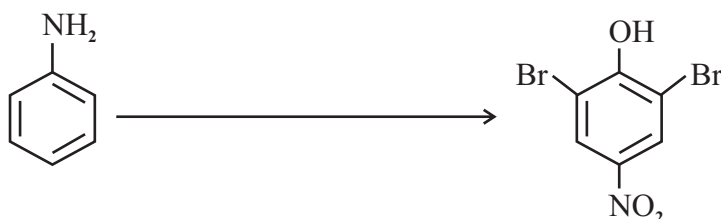

(b) Synthesis the compound X using the only organic starting material as CH_3CH_2Cl in the following reaction sequence.

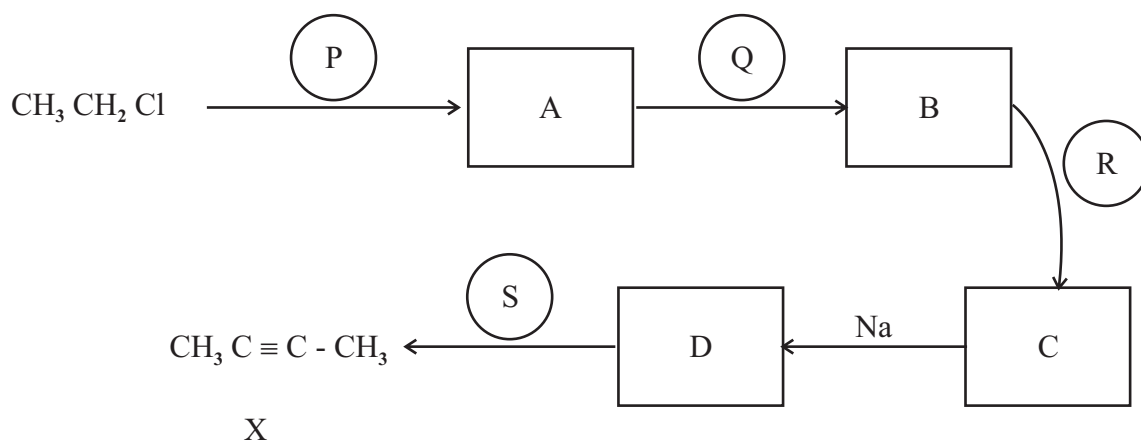

- (c) (i) Complete the following sequence of reaction to produce $\text{CH}_3\text{CH}_2\text{NHCH}_2\text{CH}_3$ using CH_3OH .

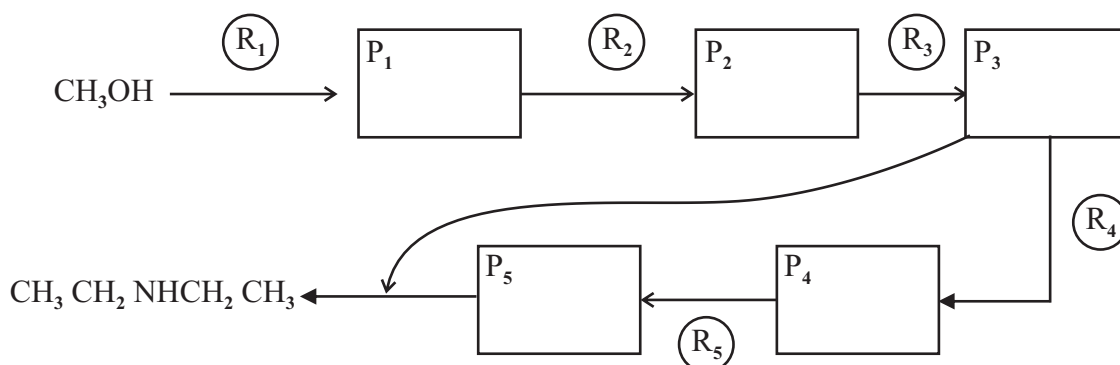

- (ii) What is the type of reaction which converts P_1 to P_2 using R_2 .

- (09) (a) ★ There are three cations contain in coloured aqueous solution P. When dil / NaOH was added to it, all 3 cations precipitate forming precipitates Q_1 , Q_2 and Q_3 .
- ★ When excess NaOH was added to the precipitate obtained above, part of the precipitate dissolves forming colourless solution R while obtained a green colour precipitate S.
- ★ When dil / H_2SO_4 was added to the colourless solution small amounts, produces a precipitate T which dissolves in conc. NH_3 .
- ★ S precipitate obtained above produces dark blue solutions U presence of excess NH_3 and gave green coloured precipitate V.
- ★ Above precipitate V turns brown when exposed to air.
- (i) Identify 3 cations in the aqueous solution P.
- (ii) Write the chemical formulae of Q_1 , Q_2 , Q_3 , S, T, V precipitates.
- (iii) Write the molecular formulae of compounds in the solutions R and U giving their IUPAC names.
- (vi) What is the compound obtained when the precipitate V exposed to air.
- (b) 20cm^3 of KMnO_4 acidified with di./ H_2SO_4 was reacted completely with 20cm^3 of H_2O_2 . Dark brown MnO_2 was obtained decolorizing equal KMnO_4 volume from 10cm^3 of $\text{MnSO}_{4(\text{aq})}$ in neutral medium. Brown precipitate was dissolved completely forming colourless solution presence of dil/ H_2SO_4 using 10cm^3 of 0.2mol dm^{-3} , $\text{Na}_2\text{C}_2\text{O}_4$.
- (i) Write the balanced chemical equation between KMnO_4 and H_2O_2 in dil/ H_2SO_4 medium.
- (ii) Write the reaction between MnSO_4 and KMnO_4 in neutral medium.
- (iii) Write the balanced chemical equation for the reaction between $\text{Na}_2\text{C}_2\text{O}_4$ and MnSO_4 in dil H_2SO_4 medium.
- (vi) Calculate the molarity of $\text{H}_2\text{O}_{2(\text{aq})}$ using the reactions written above.

- (10) (a) (i) What is polymerization?
- (ii) Consider the following polymers.
- Polyethylene
 - Teflon (PTFE)
 - Nylon 6, 6
 - Backelite
 - Polyvinyl chloride (PVC)
- (I) Write condensation polymers among the polymers given above.
- (II) Write linear polymers among them.
- (III) Draw the monomers of a, b, c polymers.
- (iii) Write two reasons for use of additives when producing polymers.
- (b) Acid rains is a main method of air pollution.
- Write 04 acidic gases added to the atmosphere due to natural activities and human activities.
 - Write natural and artificial method each, how above mentioned gases added to the atmosphere.
 - Explain using reactions, how it reduces pH value by considering one gas mentioned above.
 - Write two activities which can implement to reduce acid rains or decrease acidity of water.
- (c) Explain following situations as much as possible relevant to the chemical industries in your A/L Syllabus.
- Affect of using lime stone instead of Dolomite during the extraction of Mg metal by Dow process.
 - Advantages of using membrane cell method relevant to the Diaphragm cell when producing caustic soda.
 - Importance of using NaCl (Brine) during the production of soap.
 - Importance of the saturation of Brine solution using NH_3 before saturate it from CO_2 during the production of Na_2CO_3 from Solvay process.
 - Explain the difference of the physical properties of a type of natural rubber poly isoprene and Gutta-percha using the structure.

The Periodic Table / ආවර්තිත වගුව

1																	2	
1	H																	He
2	3	4											5	6	7	8	9	10
2	Li	Be											B	C	N	O	F	Ne
3	11	12											13	14	15	16	17	18
3	Na	Mg											Al	Si	P	S	Cl	Ar
4	19	20	21	22	23	24	25	26	27	28	29	30	31	32	33	34	35	36
4	K	Ca	Sc	Ti	V	Cr	Mn	Fe	Co	Ni	Cu	Zn	Ga	Ge	As	Se	Br	Kr
5	37	38	39	40	41	42	43	44	45	46	47	48	49	50	51	52	53	54
5	Rb	Sr	Y	Zr	Nb	Mo	Tc	Ru	Rh	Pd	Ag	Cd	In	Sn	Sb	Te	I	Xe
6	55	56	La-	72	73	74	75	76	77	78	79	80	81	82	83	84	85	86
6	Cs	Ba	Lu	Hf	Ta	W	Re	Os	Ir	Pt	Au	Hg	Tl	Pb	Bi	Po	At	Rn
7	87	88	Ac-	104	105	106	107	108	109	110	111	112	113	114	115	116	117	118
7	Fr	Ra	Lr	Rf	Db	Sg	Bh	Hs	Mt	Ds	Rg	Cn	Nh	Fl	Mc	Lv	Ts	Og

57	58	59	60	61	62	63	64	65	66	67	68	69	70	71
La	Ce	Pr	Nd	Pm	Sm	Eu	Gd	Tb	Dy	Ho	Er	Tm	Yb	Lu
89	90	91	92	93	94	95	96	97	98	99	100	101	102	103
Ac	Th	Pa	U	Np	Pu	Am	Cm	Bk	Cf	Es	Fm	Md	No	Lr

The Periodic Table / ආවර්තිත වගුව

1																	2	
1	H																	He
2	3	4											5	6	7	8	9	10
2	Li	Be											B	C	N	O	F	Ne
3	11	12											13	14	15	16	17	18
3	Na	Mg											Al	Si	P	S	Cl	Ar
4	19	20	21	22	23	24	25	26	27	28	29	30	31	32	33	34	35	36
4	K	Ca	Sc	Ti	V	Cr	Mn	Fe	Co	Ni	Cu	Zn	Ga	Ge	As	Se	Br	Kr
5	37	38	39	40	41	42	43	44	45	46	47	48	49	50	51	52	53	54
5	Rb	Sr	Y	Zr	Nb	Mo	Tc	Ru	Rh	Pd	Ag	Cd	In	Sn	Sb	Te	I	Xe
6	55	56	La-	72	73	74	75	76	77	78	79	80	81	82	83	84	85	86
6	Cs	Ba	Lu	Hf	Ta	W	Re	Os	Ir	Pt	Au	Hg	Tl	Pb	Bi	Po	At	Rn
7	87	88	Ac-	104	105	106	107	108	109	110	111	112	113	114	115	116	117	118
7	Fr	Ra	Lr	Rf	Db	Sg	Bh	Hs	Mt	Ds	Rg	Cn	Nh	Fl	Mc	Lv	Ts	Og

57	58	59	60	61	62	63	64	65	66	67	68	69	70	71
La	Ce	Pr	Nd	Pm	Sm	Eu	Gd	Tb	Dy	Ho	Er	Tm	Yb	Lu
89	90	91	92	93	94	95	96	97	98	99	100	101	102	103
Ac	Th	Pa	U	Np	Pu	Am	Cm	Bk	Cf	Es	Fm	Md	No	Lr